

# Elettropompe autoadescanti in bronzo

self priming pump in bronze

serie TSL 26/1

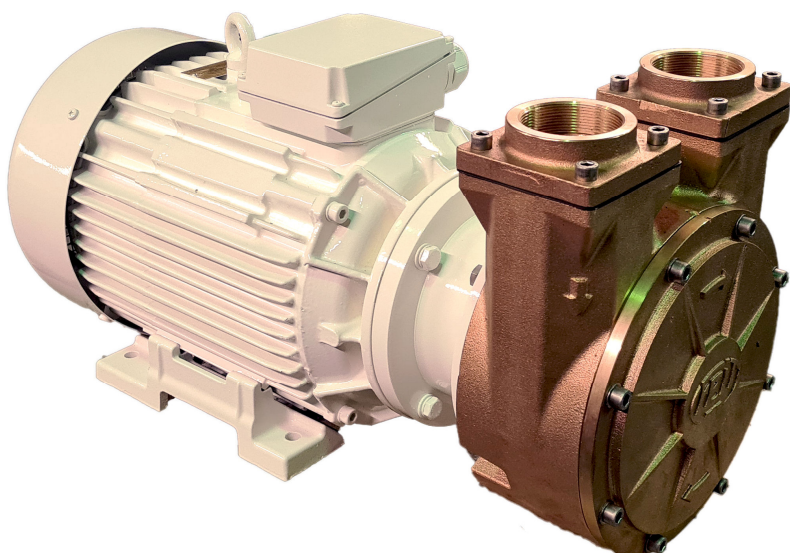

## Caratteristiche

**Corpo pompa:** bronzo  
**Girante:** bronzo  
**Diffusore:** bronzo  
**Albero:** Acciaio inox AISI 316  
**Tenuta meccanica:** Carbone - Ceramica - NBR  
**Motore:** 230/400T  
 a richiesta altre versioni  
 a richiesta esecuzione ATEX

## Characteristics

**Pump casing:** bronze  
**Impeller:** bronze  
**Diffuser:** bronze  
**Shaft:** Stainless steel AISI 316  
**Mechanical seal:** Carbon - Ceramic - NBR  
**Motor:** 230/400T  
 other version on request  
 ATEX execution on request

caratteristiche a 50 Hz  
 performance characteristics at 50Hz

TYPE	KW	l/min mc/h	100	130	150	200	240	300	350	400	450	500	550	600	650	700	750	800
			6	7.8	9	12	14,4	18	21	24	27	30	33	36	39	42	45	48
TSL 26/1A	7,5	H(m)											25	22	19	15.2	11	6
TSL 26/1B	11					60	56	51	47	42.5	38	33	28	23.5	19,5	15.2	11	6
TSL 26/1C	15			69	67	63	60	55	50	45	40	35	29,5	24	19,5	15.2	11	6

## Applicazioni

- prosciugamento sentine
- distribuzione acqua
- travaso acqua salata-dolce
- lavaggio catene
- impianti di condizionamento
- incendio

## Applications

- extracting sea water, bilge
- water supply
- transferring water and sea water
- chain washing
- conditioning system
- Fire-Fighting

### CARATTERISTICHE

- Capacità di pompare liquidi in condizioni di funzionamento continuo.
- Aspirazione fino a 7 metri
- Non necessitano valvole di ritegno.
- Funzionamento silenzioso senza vibrazioni.

### CHARACTERISTICS

- Capability of handling entrained liquids under continuous operating.
- Suction up to 7 m.
- Foot valve not required.
- Quiet operation and minimal vibration.

### TSL 26/1A

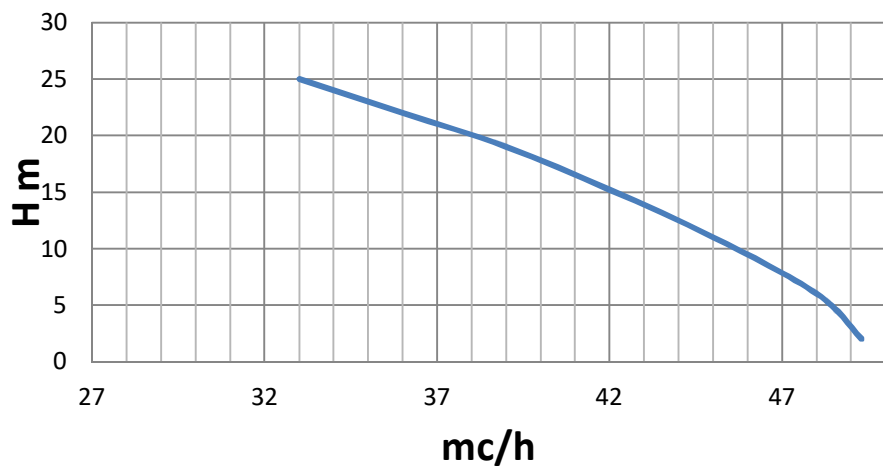

Power Kw :	7,5
volt :	230/400
rpm:	1450
Protection:	IP55
Weight Kg:	92

### TSL 26/1B

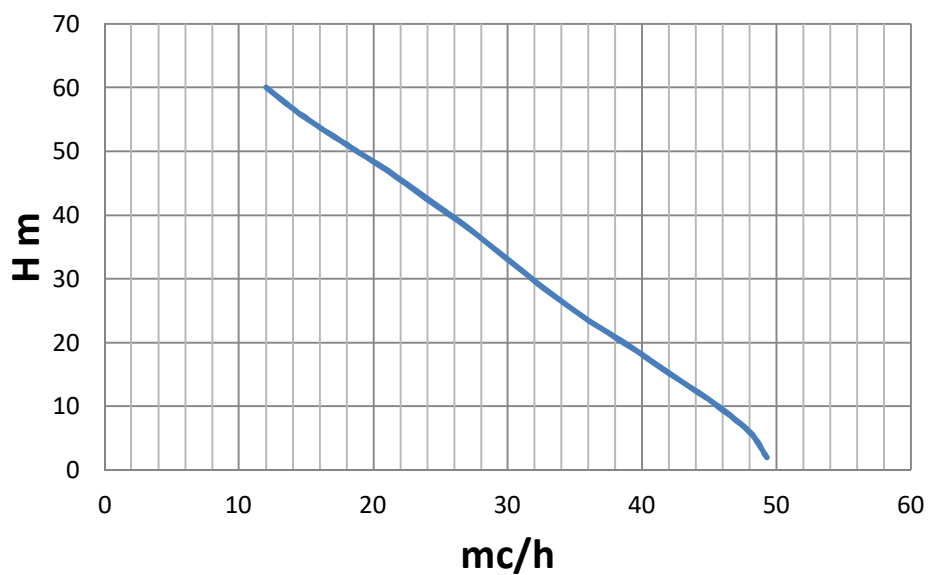

Power Kw :	11
volt :	230/400
rpm:	1450
Protection:	IP55
Weight Kg:	133

### TSL 26/1C

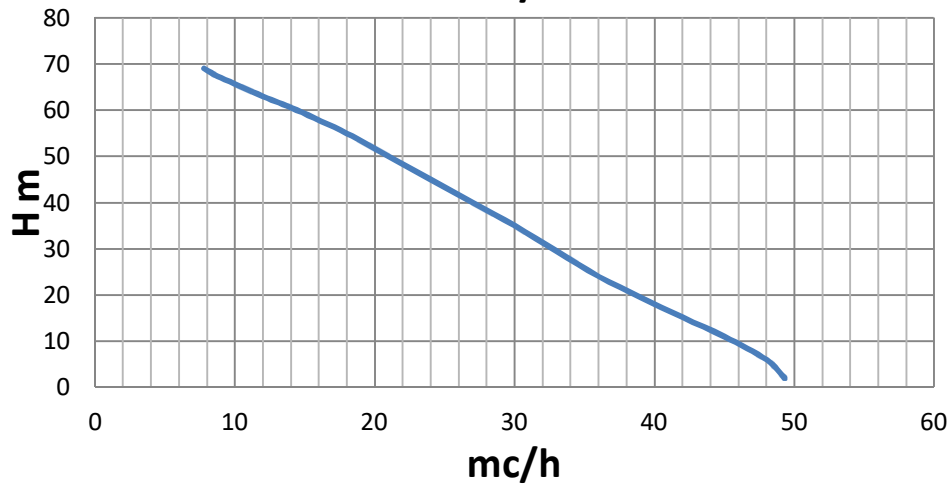

Power Kw :	15
volt :	230/400
rpm:	1450
Protection:	IP55
Weight Kg:	153

## DIMENSIONI/DIMENSIONS

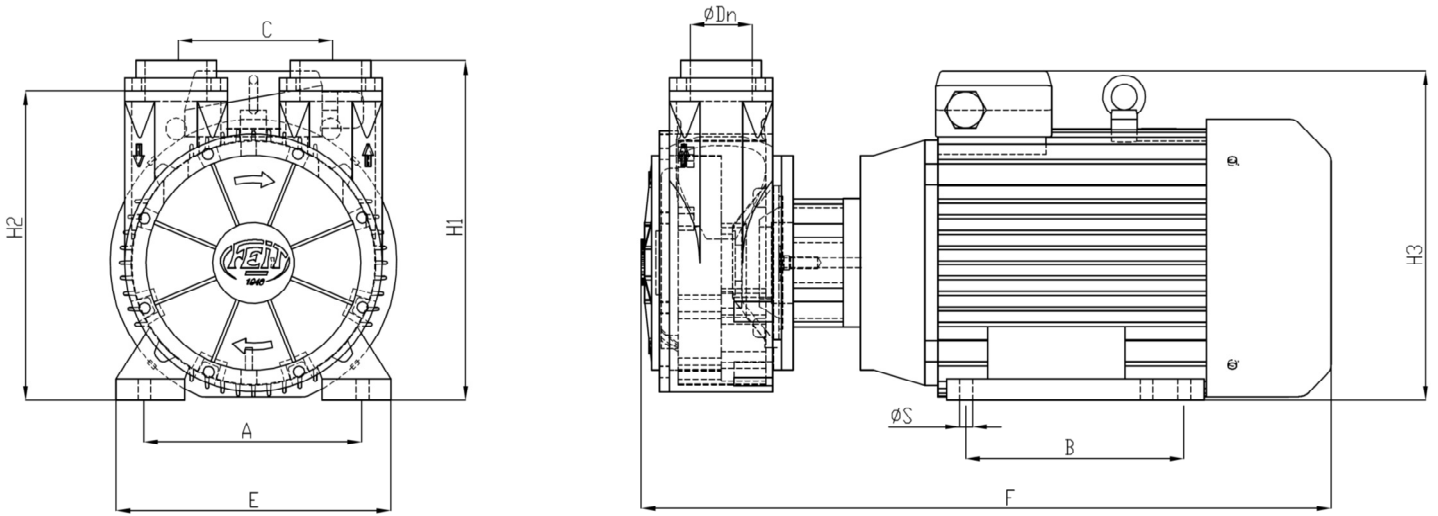

Tipo/Type	Dn	H1	H2	H3	A	E	C	B	F	S	Kg
<b>TSL26/1A</b>	2"1/2	395	360	310	216	300	180	178	710	12	92
<b>TSL26/1B</b>	2"1/2	395	360	383	254	320	180	210	750	15	133
<b>TSL26/1C</b>	2"1/2	395	360	383	254	320	180	254	803	15	153

