

# Elettropompe autoadescanti in bronzo

self priming pump in bronze

serie TSL 20/1-25/1



## Caratteristiche

**Corpo pompa:** bronzo  
**Girante** : bronzo  
**Anello tenuta su girante:** bronzo  
**Diffusore:** bronzo  
**Albero:** Acciaio inox AISI 316  
**Tenuta meccanica:** Carbone - Ceramica - NBR  
**Motore** : 24v C.C.  
 230V mon. - 230/400V Trifase  
 a richiesta altre versioni  
 a richiesta esecuzione ATEX

## Characteristics

**Pump casing:** bronze  
**Impeller** : bronze  
**Wear-ring impeller-diffuser:** bronze  
**Diffuser:** bronze  
**Shaft:** Stainless steel AISI 316  
**Mechanical seal:** Carbon - Ceramic - NBR  
**Motor** : 24V d.c.  
 230V 1ph - 230/400V 3ph  
 other version on request  
 ATEX execution on request

caratteristiche //performance

| TYPE      | KW   | l/min<br>mc/h | 5   | 10  | 20  | 25  | 40  | 45   | 60  | 75  | 100 | 125 | 130  | 150 | 175  | 200 | 225  | 240  | 265  | 300 | 350 | 400 | 450 |   |
|-----------|------|---------------|-----|-----|-----|-----|-----|------|-----|-----|-----|-----|------|-----|------|-----|------|------|------|-----|-----|-----|-----|---|
|           |      |               | 0,3 | 0,6 | 1,2 | 1,5 | 2,4 | 2,7  | 3,6 | 4,5 | 6   | 7,5 | 7,8  | 9   | 10,5 | 12  | 13,5 | 14,4 | 15,9 | 18  | 21  | 24  | 27  |   |
| TSL 20-1  | 0,75 | H(m)          | 39  | 37  | 35  | 34  | 30  | 29   | 25  | 20  | 10  | 2   |      |     |      |     |      |      |      |     |     |     |     |   |
| TSL 23-1  | 1,1  |               |     |     | 39  | 38  | 35  | 34   | 30  | 27  | 20  | 14  | 12,5 | 6   |      |     |      |      |      |     |     |     |     |   |
| TSL 23-2  | 2,2  |               |     |     |     | 60  | 52  | 49,5 | 43  | 37  | 28  | 19  | 17   | 8   |      |     |      |      |      |     |     |     |     |   |
| TSL 24-1  | 2,2  |               |     |     |     |     |     |      |     |     | 35  | 29  | 28   | 23  | 18   | 13  | 8    |      |      |     |     |     |     |   |
| TSL 24-2  | 4    |               |     |     |     |     |     |      |     | 71  | 65  | 56  | 446  | 43  | 35   | 26  | 18   | 10   | 5    |     |     |     |     |   |
| TSL 25-1A | 3    |               |     |     |     |     |     |      |     |     |     |     |      |     |      |     | 23   | 20   | 18   | 15  | 10  | 5   | 2   |   |
| TSL 25-1  | 4    |               |     |     |     |     |     |      |     |     |     |     |      |     |      |     | 36   | 33   | 31   | 28  | 24  | 17  | 10  | 2 |

## Applicazioni

- prosciugamento sentine
- distribuzione acqua
- travaso acqua salata-dolce
- lavaggio catene
- impianti di condizionamento
- incendio

## Applications

- extracting sea water, bilge
- water supply
- transferring water and sea water
- chain washing
- conditioning system
- Fire-Fighting

### CARATTERISTICHE

- Capacità di pompare liquidi in condizioni di funzionamento continuo.
- Aspirazione fino a 7 metri
- Non necessitano valvole di ritegno.
- Funzionamento silenzioso senza vibrazioni.

### CHARACTERISTICS

- Capability of handling entrained liquids under continuous operating.
- Suction up to 7 m.
- Foot valve not required.
- Quiet operation and minimal vibration.

### TSL 20-1

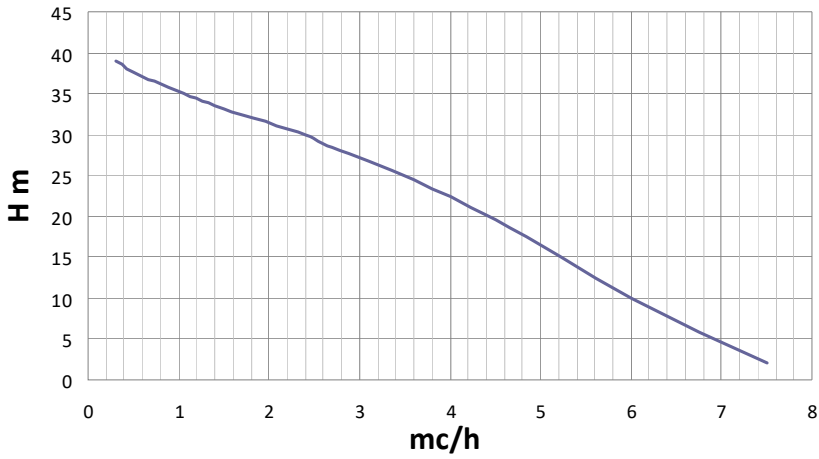

|            |         |      |      |
|------------|---------|------|------|
| Power Kw:  | 0.75    |      |      |
| volt :     | 230/400 | 230m | 24V  |
| rpm:       | 1450    |      | 1700 |
| Weight Kg: | 23      |      | 26   |

### TSL 23-1

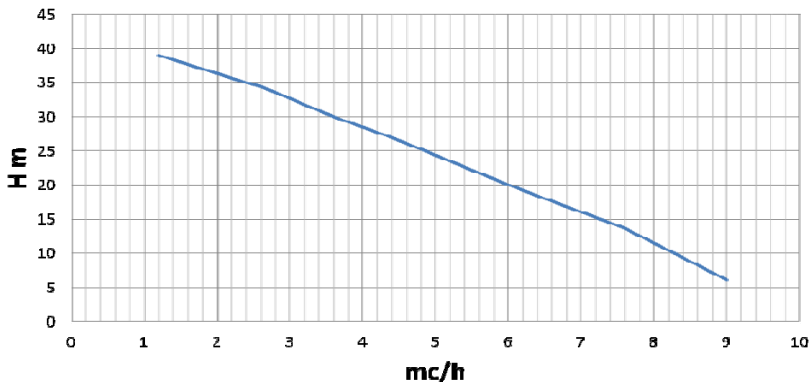

|            |         |      |      |
|------------|---------|------|------|
| Power Kw:  | 1.1     |      |      |
| volt :     | 230/400 | 230m | 24V  |
| rpm:       | 1450    |      | 1700 |
| Weight Kg: | 29      |      | 26   |

### TSL 23-2

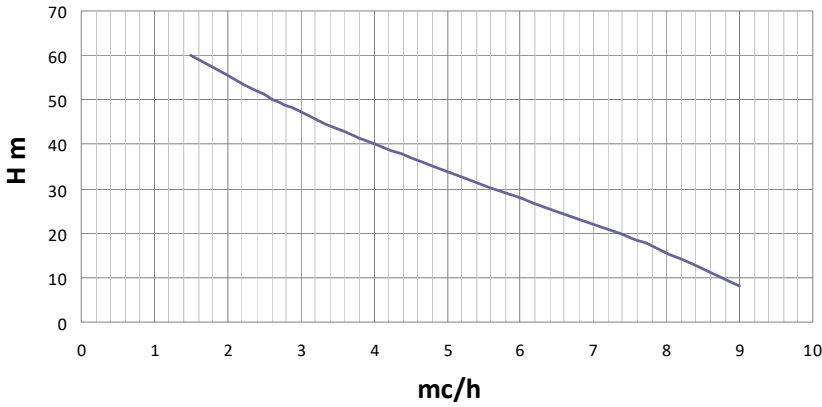

|            |         |      |      |
|------------|---------|------|------|
| Power Kw:  | 2.2     |      |      |
| volt :     | 230/400 | 230m | 24V  |
| rpm:       | 1450    |      | 1450 |
| Weight Kg: | 45      |      | 38   |

### TSL 24-1

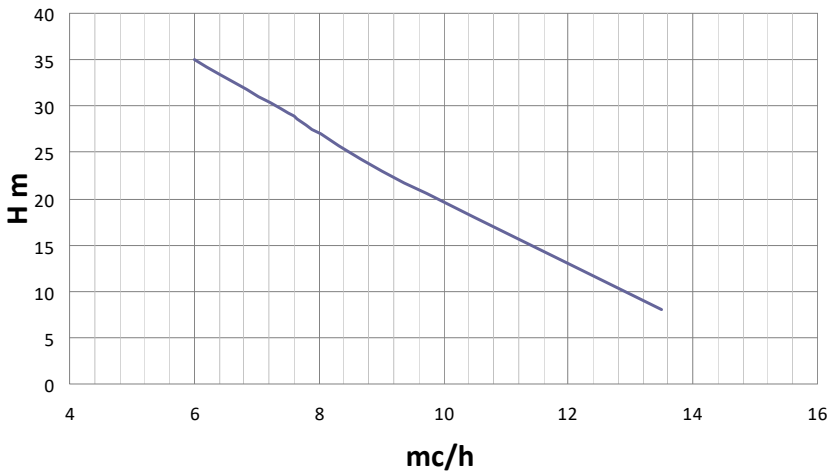

|            |         |      |      |
|------------|---------|------|------|
| Power Kw:  | 2.2     |      |      |
| volt :     | 230/400 | 230m | 24V  |
| rpm:       | 1450    |      | 1450 |
| Weight Kg: | 46      |      | 39   |

### TSL 24-2

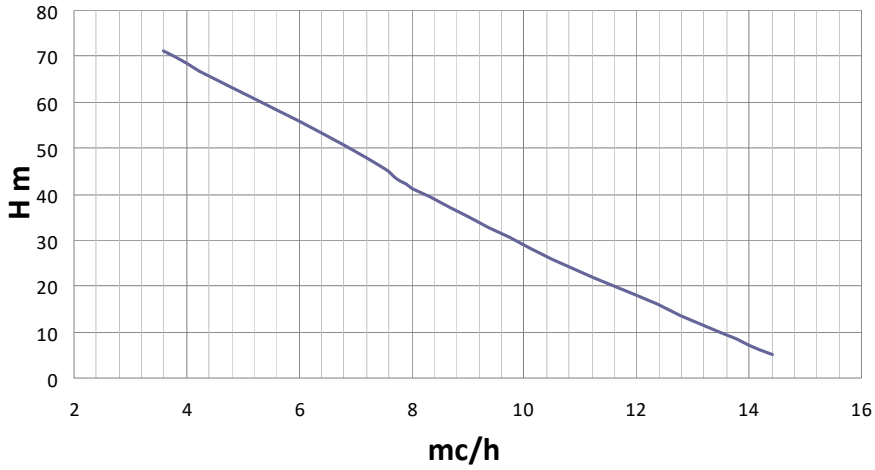

|            |         |      |
|------------|---------|------|
| Power Kw:  | 4       |      |
| volt :     | 230/400 | 230m |
| rpm:       | 1450    |      |
| Weight Kg: | 59      |      |

### TSL 25/1A

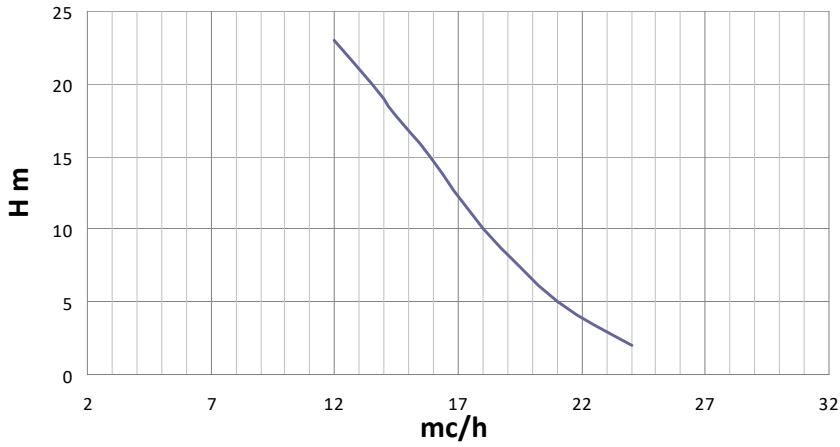

|            |         |      |      |
|------------|---------|------|------|
| Power Kw:  | 3       |      |      |
| volt :     | 230/400 | 230m | 24V  |
| rpm:       | 1450    |      | 1450 |
| Weight Kg: | 53      | 45   |      |

### TSL 25/1

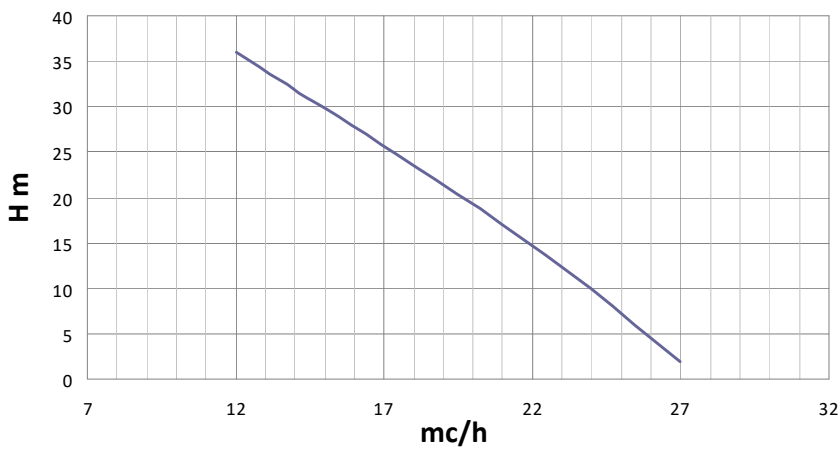

|            |         |      |
|------------|---------|------|
| Power Kw:  | 4       |      |
| volt :     | 230/400 | 230m |
| rpm:       | 1450    |      |
| Weight Kg: | 61      |      |

Dimensioni corrente alternata //Dimensions AC execution

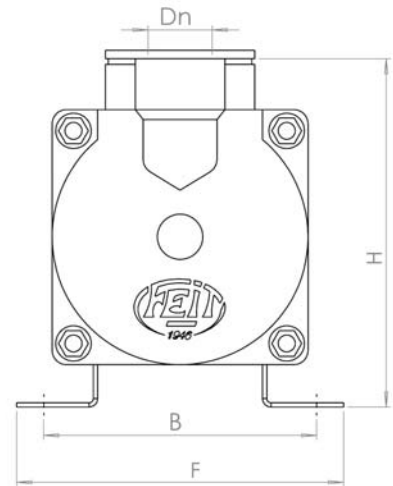
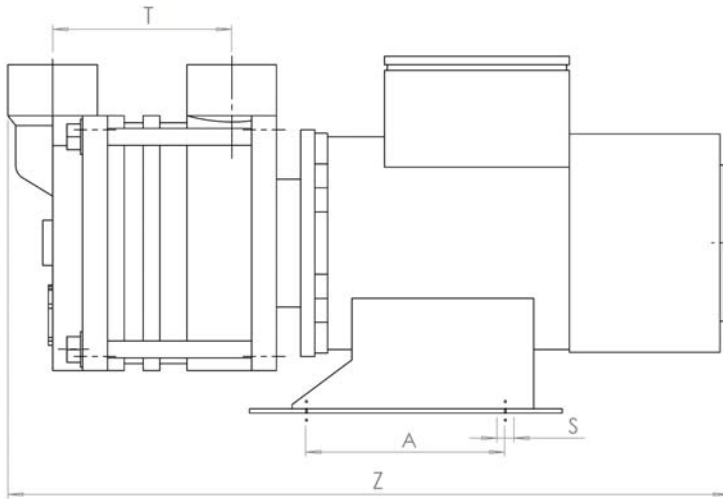

| TYPE      | Dn     | A   | B   | F   | H   | S  | T   | Z   | Kg |
|-----------|--------|-----|-----|-----|-----|----|-----|-----|----|
| TSL 20-1  | 1"1/4G | 100 | 125 | 155 | 210 | 9  | 105 | 430 | 26 |
| TSL 23-1  | 1"1/4G | 140 | 192 | 230 | 228 | 12 | 105 | 485 | 34 |
| TSL 23-2  | 1"1/4G | 140 | 192 | 230 | 228 | 12 | 130 | 500 | 38 |
| TSL 24-1  | 1"1/2G | 140 | 192 | 230 | 250 | 12 | 125 | 510 | 39 |
| TSL 25-1A | 2"G    | 140 | 192 | 230 | 260 | 12 | 165 | 560 | 45 |

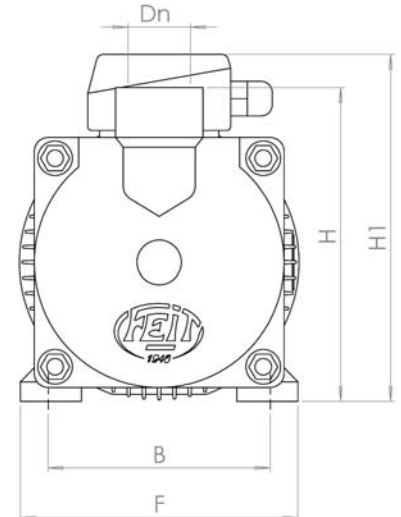
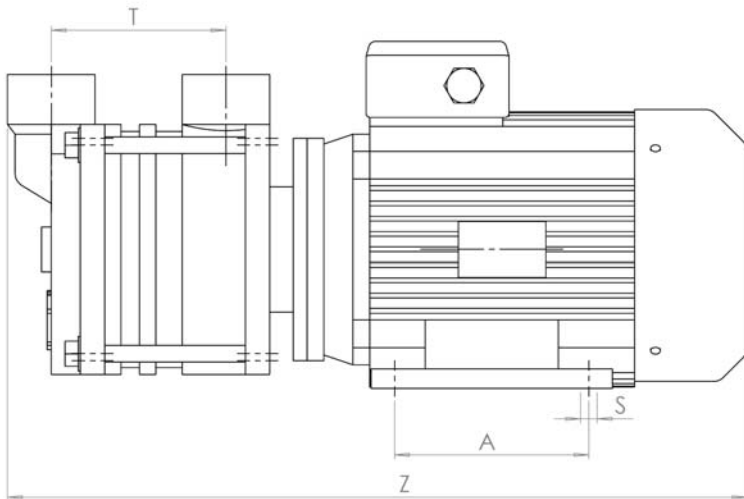

Dimensioni corrente continua //Dimensions DC execution

| TYPE      | Dn     | A   | B   | F   | H   | H1  | S  | T   | Z   | Kg |
|-----------|--------|-----|-----|-----|-----|-----|----|-----|-----|----|
| TSL 20-1  | 1"1/4G | 100 | 125 | 160 | 188 | 198 | 10 | 105 | 430 | 23 |
| TSL 23-1  | 1"1/4G | 125 | 140 | 170 | 198 | 228 | 10 | 105 | 490 | 29 |
| TSL 23-2  | 1"1/4G | 140 | 160 | 200 | 210 | 250 | 12 | 130 | 520 | 45 |
| TSL 24-1  | 1"1/2G | 140 | 160 | 200 | 230 | 250 | 12 | 125 | 530 | 46 |
| TSL 24-2  | 1"1/2G | 140 | 190 | 230 | 240 | 280 | 12 | 180 | 590 | 59 |
| TSL 25-1A | 2"G    | 140 | 160 | 205 | 240 | 250 | 12 | 165 | 580 | 53 |
| TSL 25-1  | 2"G    | 140 | 190 | 230 | 250 | 276 | 12 | 165 | 600 | 61 |