

POMPE MANUALI AUTOADESCANTI

Serie EXCELSIOR

SELF PRIMING HAND PUMPS

POMPE MANUELLE AUTO-AMORÇANTES

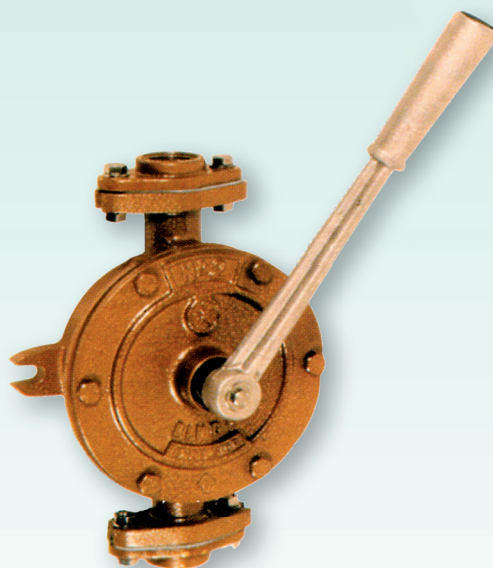

LA POMPA EXCELSIOR È PARTICOLARMENTE INDICATA PER:

- ACQUA DI MARE, SENTINE DI VEICOLI ANFIBI E IMBARCAZIONI,.
- TRAVASO CARBURANTI IN GENERE: BENZINA. GASOLIO, KEROSENE, PETROLIO, NAFTA E OLI FLUIDI ECC.
- PROSCIUGAMENTO SCANTINATI, CUNICOLI, INTERCAPEDINI, POZZETTI PER CAVI ELETTRICI E TELEFONICI.
- PROSCIUGAMENTO POZZETTI DEI DISTRIBUTORI DI CARBURANTI.

THIS EXCELSIOR PUMP IS PARTICULARLY SUITABLE FOR:

- SEAWATER, BILGE OF AMPHIBIAN VEHICLES AND CRAFTS.
- DECANTING FUELS USUALLY: PETROL, DIESEL, KEROSENE, OIL, NAPHTHA AND FLUID OILS, ETC.
- DRAINING OF BASEMENTS, UNDERGROUND PASSAGES, DRAINS FOR ELECTRICAL AND PHONE CABLES
- DRAINING WELLS OF FUEL DISTRIBUTORS.

LA POMPE EXCELSIOR EST PARTICULIÈREMENT INDICUÉE POUR:

- EAU DE MER, SENTINES DE VÉHICULES AMPHIBIES ET EMBARCATIONS.
- TRANSFERT CARBURANTS EN TOUT GENRE: ESSENCE. GAZOLE, KÉROSÈNE, PÉTROLE, MAZOUT ET HUILES FLUIDES ETC.
- ASSÈCHEMENT SOUS-SOLS, CANIVEAUX, GAINES, PUIS POUR CÂBLES ÉLECTRIQUES ET TÉLÉPHONIQUES.
- ASSÈCHEMENT PUIS DES DISTRIBUTEURS DE CARBURANTS.

Tipo Type	Portata Capacity Débit l/min	Mandata Delivery Distribution m	Bocche Connection	Aspirazione Suction Aspiration m	Peso Weight Poids Kg
0	16	15	1/2"gas	7	3,3
1	20	20	3/4"gas	7	4,5
2	30	20	1"gas	8	5,5
3	40	20	1"1/4gas	8	8,3
4	55	20	1"1/4gas	8	10
5	80	20	1"1/2 gas	8	13

DIMENSIONI E PESI - DIMENSIONS AND WEIGHTS - DIMENSIONS ET POIDS

MATERIALI DI COSTRUZIONE:

- (B) : Costruzione in bronzo
- (G) : Costruzione in ghisa

MATERIAL OF ONSTRUCTION:

- (B) : bronze
- (G) : cast iron

MATERIAUX DE CONSTRUCTION:

- (B) : bronze
- (G) : cast iron

La pompa EXCELSIOR è particolarmente indicata per:

- Acqua di mare, sentine di veicoli anfibi e imbarcazioni.
- Travaso carburanti in genere: benzina, gasolio, kerosene, petrolio, nafta e oli fluidi ecc.
- Prosciugamento scantinati, cunicoli, intercapedini, pozzetti per cavi elettrici e telefonici.
- Prosciugamento pozzetti dei distributori di carburanti.

This EXCELSIOR pump is particularly suitable for:

- Seawater, bilge of amphibian vehicles and crafts.
- Decanting fuels usually: petrol, diesel, kerosene, oil, naphtha and fluid oils, etc.
- Draining of basements, underground passages, drains for electrical and phone cables
- Draining wells of fuel distributors.

La pompe EXCELSIOR est Particulièrement indiquée pour:

- Eau de mer, sentines de véhicules amphibies et embarcations.
- Transfert carburants en tout genre: essence, gazole, kerosène, pétrole, mazout et huiles fluides etc.
- Assèchement sous-sols, caniveaux, gaines, puits pour câbles électriques et téléphoniques.
- Assèchement puits des distributeurs de carburants.

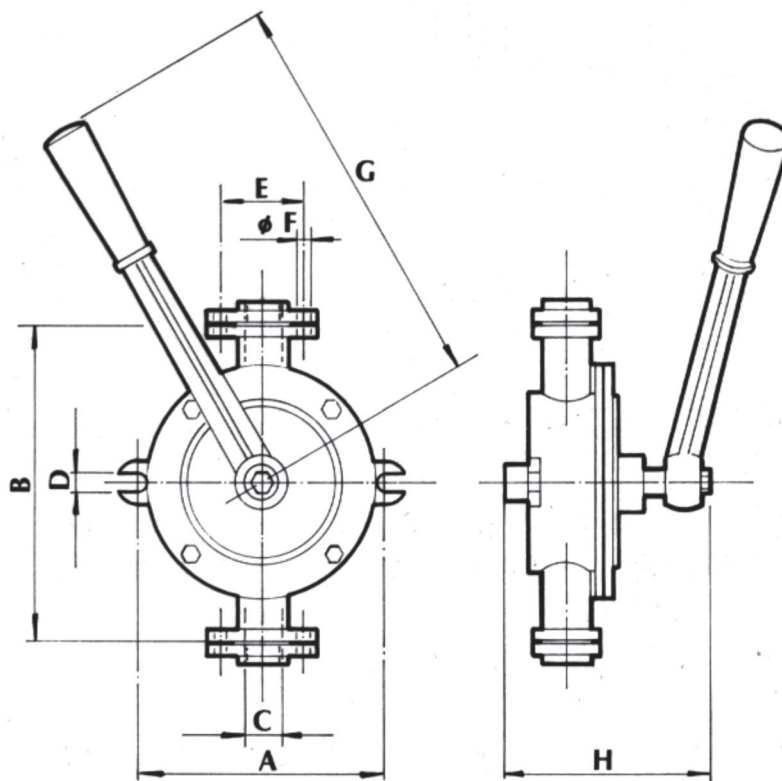

QUOTE DI INGOMBRO / DIMENSIONS

Tipo Type	A	B	C	D	E	F	G	H
0	125	175	1/2"	9	43	7	260	136
1	150	205	3/4"	11	55	7	260	136
2	170	230	1"	12	64	9	260	138
3	190	260	1"1/4	12	74	9	320	166
4	220	285	1"1/4	12	74	9	410	185
5	250	320	1"1/2	15	85	9	410	185