

POMPE MANUALI AUTOADESCANTI

Serie SUPER LARIO

SELF PRIMING HAND PUMPS

POMPE MANUELLE AUTO-AMORÇANTES

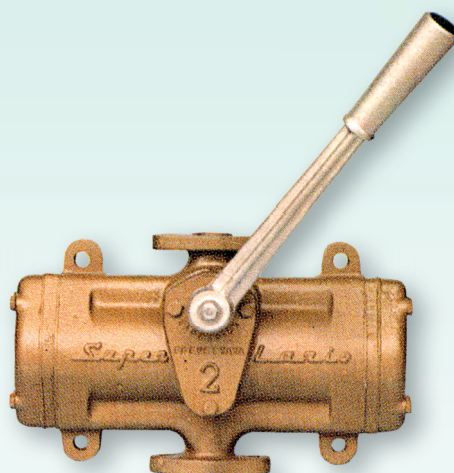

LE CARATTERISTICHE PRINCIPALI SONO:

- AUTOINNESCO IMMEDIATO SENZA PREVENTIVO RIEMPIMENTO DEL CORPO POMPA.
- MASSIMA SICUREZZA DI FUNZIONAMENTO ANCHE DOPO VARI MESI D'INATTIVITÀ.
- NON NECESSITA VALVOLA DI FONDO, NÉ SUCCHERUOLA, NÉ FILTRO.
- MANUTENZIONE NULLA.
- ESTREMA FACILITÀ DI SMONTAGGIO.

MAIN CHARACTERISTICS:

- IMMEDIATE SELF-PRIMING WITHOUT PRE-FILLING THE BODY OF THE PUMP.
- MAXIMUM RELIABILITY OF OPERATION, EVEN AFTER BEING INACTIVE FOR LENGTHY PERIODS.
- NO FOOT VALVES, NO FILTER.
- NO MAINTENANCE REQUIRED.
- QUICK INSTALLATION.

CARACTÉRISTIQUES:

- AUTO-AMORÇAGE IMMÉDIAT SANS REMPLISSAGE PRÉVENTIF DU CORPS POMPE.
- SÉCURITÉ MAXIMUM DE FONCTIONNEMENT MÊME APRÈS DIVERS MOIS D'INACTIVITÉ.
- NE NÉCESSITE PAS DE SOUPAPE DE FOND, NI FILTRE.
- ENTRETIEN NUL
- EXTRÊME FACILITÉ DE DÉMONTAGE.

Tipo Type	Portata Capacity Débit l/min	Mandata Delivery Distribution m	Bocche Connection	Aspirazione Suction Aspiration m
2	35	30	1"gas	8
3	50	30	1"1/4gas	8
4	70	30	1"1/2gas	8
5	100	30	2" gas	8

DIMENSIONI E PESI - DIMENSIONS AND WEIGHTS - DIMENSIONS ET POIDS

MATERIALI DI COSTRUZIONE:

(B) :Costruzione in bronzo
(G) :Costruzione in ghisa

MATERIAL OF ONSTRUCTION:

(B) : bronze
(G) : cast iron

MATERIAUX DE CONSTRUCTION:

(B) : bronze
(G) : cast iron

La pompa SUPER LARIO è particolarmente indicata per:

- Acqua di mare, sentine di veicoli anfibi e imbarcazioni,.
- Travaso carburanti in genere: benzina, gasolio, kerosene, petrolio, nafta e oli fluidi ecc.
- Prosciugamento scantinati, cunicoli, intercapedini, pozzetti per cavi elettrici e telefonici.
- Prosciugamento pozzetti dei distributori di carburanti.

This SUPER LARIO pump is particularly suitable for:

- Seawater, bilge of amphibian vehicles and crafts.
- Decanting fuels usually: petrol, diesel, kerosene, oil, naphtha and fluid oils, etc.
- Draining of basements, underground passages, drains for electrical and phone cables
- Draining wells of fuel distributors.

La pompe SUPER LARIO est Particulièrement indiquée pour:

- Eau de mer, sentines de véhicules amphibies et embarcations.
- Transfert carburants en tout genre: essence, gazole, kérosène, pétrole, mazout et huiles fluides etc.
- Assèchement sous-sols, caniveaux, gaines, puits pour câbles électriques et téléphoniques.
- Assèchement puits des distributeurs de carburants.

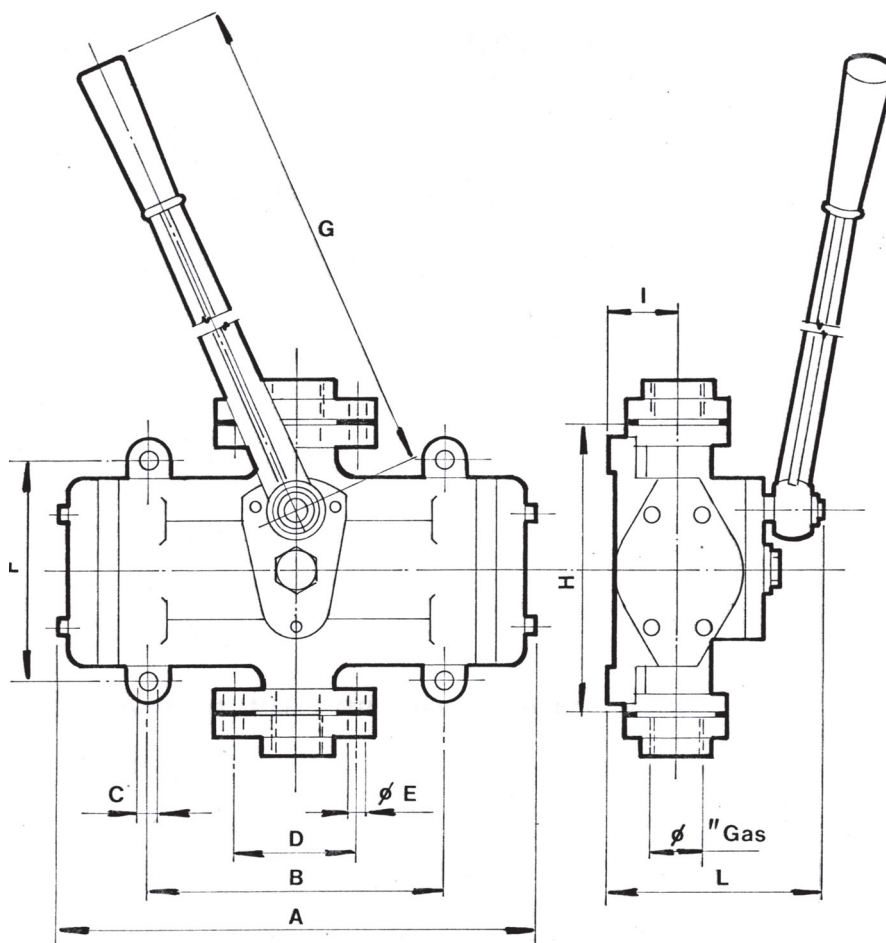

QUOTE DI INGOMBRO / DIMENSIONS

TYPE	F	A	B	C	D	E	F	G	H	I	L	KG
2	1"	280	185	11	64	9	132	270	170	39	130	8
3	1"1/4	210	210	13	74	9	165	330	200	45	165	11
4	1"1/2	370	250	13	85	9	190	500	250	50	190	15
5	2"	480	340	13	85	9	220	500	260	65	220	23