

MOTOPOMPE AUTOADESCANTI

Serie PG

SELF PRIMING MOTOR PUMPS

MOTOPOMPES AUTO-AMORCANTES

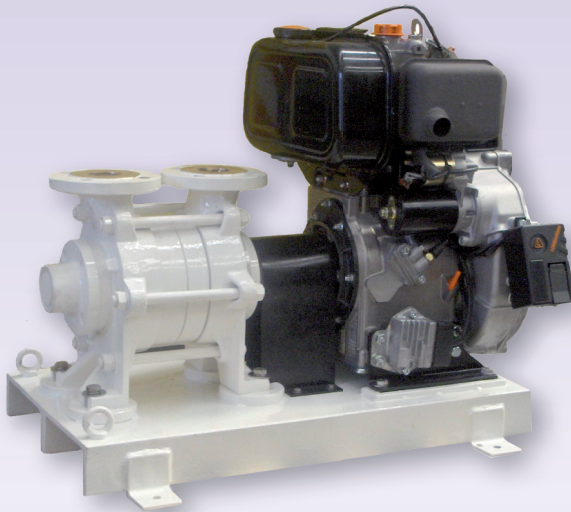

VTA501XRD



V2XRD

CARATTERISTICHE:

CORPO: BRONZO
GIRANTE: BRONZO
ALBERO: ACCIAIO INOX AISI 316
TENUTA: MECCANICA
MOTORE: DIESEL, BENZINA,
AVVIAMENTO ELETTRICO A RICHIESTA

CHARACTERISTICS:

BODY: BRONZE
IMPELLER: BRONZE
SHAFT: STAINLESS STEEL AISI 316
MECHANICAL SEAL
MOTOR: DIESEL OR GASOLINE
ELECTRIC STARTER: ON REQUEST

CARACTÉRISTIQUES:

CORPS: BRONZE
TURBINE: BRONZE
ARBRE: L'ACIER AISI 316
GARNITURE: MÉCANIQUE
MOTEUR: GAS-OIL OU ESSENCE
STARTER ÉLECTRIQUE: SUR DEMANDE



Motopompe centrifughe ed autoadescenti, sia con girante aperta che con girante chiusa, per impieghi diversificati. Sono accoppiate con motori di primarie case nazionali nella versione diesel o benzina.

A richiesta possiamo proporre le motopompe con allestimenti speciali su telaio o carrelli trainabili e dotate di tutti gli accessori.

Trovano vasti impieghi:

- in agricoltura, per irrigazione a pioggia o scorrimento;
- nella protezione civile, per svuotamenti d'emergenza;
- nell'edilizia, per lo svuotamento di scavi;
- nell'industria, per antincendio.
- nella nautica, per sentine e impianti antincendio



Centrifugal and self priming motorpumps with open and/or closed impeller, suitable for different employments. They are assembled to diesel or gasoline Italian engines. On demand, the motorpumps can be mounted on base plate or trolleys, supplied with every necessary accessories

- for agriculture, sprinkler or sliding irrigations;
- for civil protection and emergency;
- for building and industry;
- for fire-fighting systems, and bilge.

Motopompes centrifuges et auto-amorçantes, avec roue ouverte et roue fermée, pour des emplois diversifiés.

Elles sont accouplées avec des moteurs des plus grands constructeurs nationaux dans la version gazole ou essence.

Sur demande nous pouvons proposer des motopompes avec équipements spéciaux sur châssis ou chariots tractables et dotées de tous les accessoires d'usage.

Elles trouvent de vastes applications dans:

- l'agriculture, par irrigation ou pluie ou écoulement;
- la protection civile, pour extractions urgentes;
- le bâtiment, pour l'extraction de tranchées;
- l'industrie, pour la protection contre les incendies.
- des cales et dans les systèmes de protection contre les incendies

DIMENSIONI E PESI - DIMENSIONS AND WEIGHTS - DIMENSIONS ET POIDS

TSL 40-50

V 2-3-4XRD

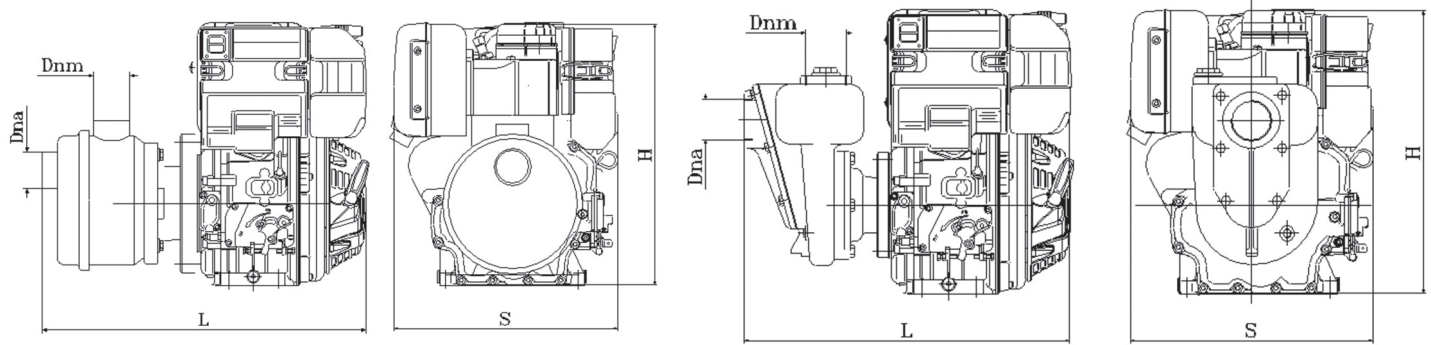

TIPO TYPE	Kw	motore	Giri	I/min	m							Dimensioni /Dimension					Peso Kg
					5	10	20	30	35	40	45	L	S	H	Dna	Dnm	
V40TSLD	6	Diesel	2500		370	350	290	150	120			600	390	410	40	40	43
V50TSLD	6	Diesel	2500		430	400	350	230	85	70		650	390	410	50	50	48
V25TSLD	6	Diesel	2000		450	415	360	305	230			730	400	430	1"1/2	1"1/2	55
V2XRD	3	Diesel	3600		510	450	420	350	250	200	150	500	380	445	2"	2"	45
V3XRD	4,7	Diesel	3600		1200	1000	600	300				545	390	445	3"	3"	65
V4XRD	6,6	Diesel	3600		1500	1300	1200	1000	800	600		620	466	570	4"	4"	75
V4XRRD	10,3	Diesel	3600		2300	2200	1500	700	610			770	466	580	4"	4"	95

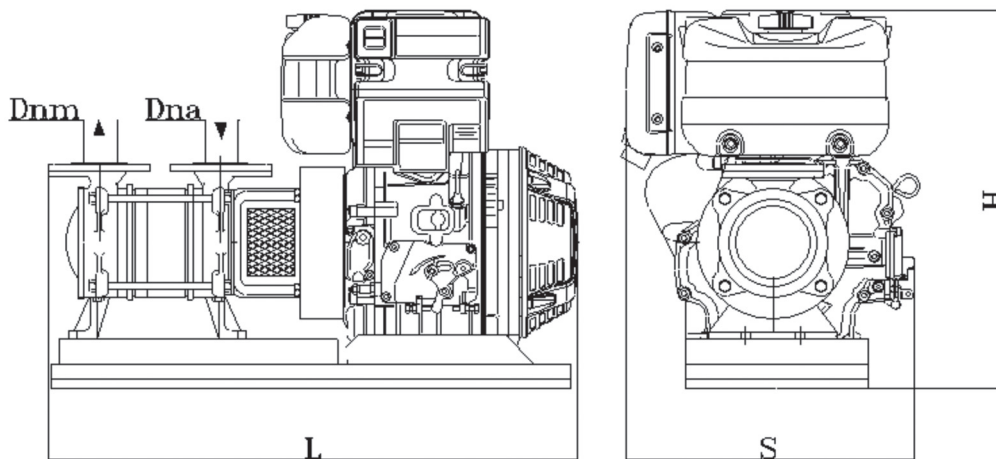

TIPO TYPE	Kw	motore	Giri	I/min	m						Dimensioni/Dimensions					
					20	30	40	50	60	70	75	L	S	H	Dna	Dnm
VTA 402	6	Diesel	1700		200	180	160	140	100			500	380	445	40	40
VTA 501	9	Diesel	1700		415	360	305	230				545	390	445	50	50
VTA 502	9	Diesel	1600		430	380	320	280	250	220	200	620	466	570	50	50
VTA 503	12	Diesel	1700		700	600	510	450	400			770	466	580	65	65